

## 1. Shape and Dimension (Unit:mm)

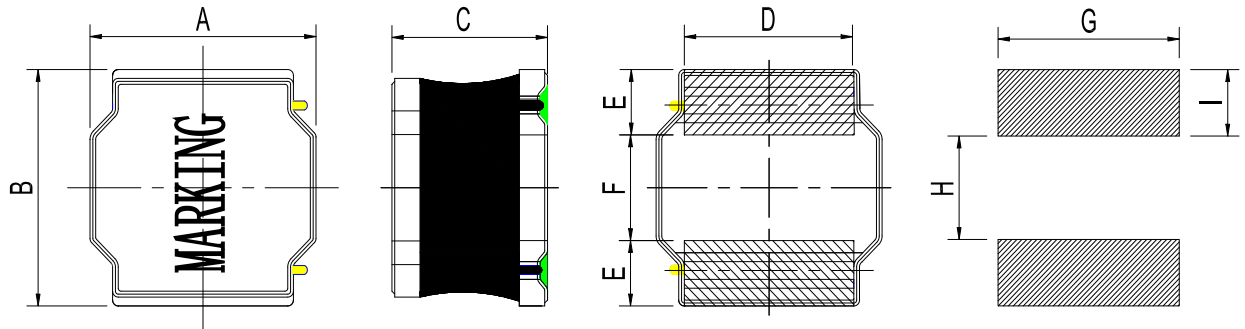

TYPE	A	B	C <sub>Max</sub>	D	E	F	G ref	H ref	I ref
CR252010	2.0±0.1	2.5±0.1	1.0	1.5±0.2	0.8±0.2	0.8±0.2	2.0	0.8	0.85
CR252012	2.0±0.1	2.5±0.1	1.2	1.5±0.2	0.8±0.2	0.8±0.2	2.0	0.8	0.85
CR3012	3.0±0.2	3.0±0.2	1.2	2.5±0.2	0.75±0.2	1.5±0.2	2.7	1.5	0.8
CR3015	3.0±0.2	3.0±0.2	1.5	2.5±0.2	0.75±0.2	1.5±0.2	2.7	1.5	0.8
CR4018	4.0±0.2	4.0±0.2	1.85	3.3±0.2	0.95±0.2	2.1±0.2	3.7	1.9	1.1
CR4020	4.0±0.2	4.0±0.2	2.1	3.3±0.3	1.0±0.2	2.0±0.3	3.7	1.9	1.1
CR4030	4.0±0.2	4.0±0.2	3.0	3.3±0.3	1.0±0.2	2.0±0.3	3.7	1.9	1.1
CR5015	5.0±0.2	5.0±0.2	1.5	4.0±0.3	1.35±0.2	2.3±0.3	4.2	2.3	1.4
CR5020	5.0±0.2	5.0±0.2	2.2	4.0±0.3	1.35±0.2	2.3±0.3	4.2	2.3	1.4
CR5030	5.0±0.2	5.0±0.2	3.0	4.0±0.3	1.35±0.2	2.3±0.3	4.2	2.3	1.4
CR5040	5.0±0.2	5.0±0.2	4.0	4.0±0.3	1.35±0.2	2.3±0.3	4.2	2.3	1.4
CR6015	6.0±0.3	6.0±0.3	1.8	4.9±0.3	1.55±0.3	2.9±0.3	5.7	2.8	1.7
CR6020	6.0±0.3	6.0±0.3	2.0	4.9±0.3	1.55±0.3	2.9±0.3	5.7	2.8	1.7
CR6028	6.0±0.3	6.0±0.3	2.8	4.9±0.3	1.7±0.3	2.9±0.3	5.7	2.8	1.7
CR6045	6.0±0.3	6.0±0.3	4.5	4.9±0.3	1.55±0.3	2.9±0.3	1.7	2.8	5.7
CR8040	8.0±0.3	8.0±0.3	4.2	6.3±0.3	2.0±0.3	4.0±0.3	7.5	3.8	2.2

## 2. Electronic Characteristics List

Part Number	Inductance (uH)	Tolerance (±%)	DCR(mΩ) ±25%	I <sub>sat</sub> (A)	I <sub>rise</sub> (A)	Test Condition
CR252010-R68N	0.68	30	62	2.20	2.00	100KHz /0.25V
CR252010-1R0N	1.0	30	90	1.85	1.65	100KHz /0.25V
CR252010-1R5M	1.5	20	152	1.80	1.30	100KHz /0.25V
CR252010-2R2M	2.2	20	174	1.20	1.20	100KHz /0.25V
CR252010-3R3M	3.3	20	273	1.05	0.90	100KHz /0.25V
CR252010-4R7M	4.7	20	469	0.95	0.70	100KHz /0.25V
CR252010-6R8M	6.8	20	747	0.78	0.59	100KHz /0.25V
CR252010-100M	10	20	910	0.65	0.50	100KHz/0.25V

Part Number	Inductance (uH)	Tolerance (±%)	DCR(mΩ) ±25%	Isat (A)	Irise (A)	Test Condition
CR252012-R68N	0.68	30	73	2.70	1.73	100KHz /0.25V
CR252012-1R0N	1.0	30	85	2.68	1.58	100KHz /0.25V
CR252012-1R5M	1.5	20	113	2.24	1.40	100KHz /0.25V
CR252012-2R2M	2.2	20	165	1.85	1.15	100KHz /0.25V
CR252012-3R3M	3.3	20	200	1.61	1.04	100KHz /0.25V
CR252012-4R7M	4.7	20	315	1.18	0.84	100KHz /0.25V
CR252012-6R8M	6.8	20	447	0.98	0.69	100KHz /0.25V
CR252012-8R2M	8.2	20	506	0.98	0.65	100KHz /0.25V
CR252012-100M	10	20	575	0.88	0.62	100KHz/0.25V
Part Number	Inductance (uH)	Tolerance (±%)	DCR(mΩ) ±30%	Isat (A)	Irise (A)	Test Condition
CR3012-R33N	0.33	30	21	3.00	2.90	100KHz /0.25V
CR3012-R47N	0.47	30	33	2.20	2.20	100KHz /0.25V
CR3012-R82N	0.82	30	40	2.05	2.10	100KHz /0.25V
CR3012-1R0N	1.0	30	48	1.90	2.00	100KHz /0.25V
CR3012-1R5N	1.5	30	55	1.62	1.85	100KHz /0.25V
CR3012-2R2M	2.2	20	75	1.20	1.55	100KHz /0.25V
CR3012-3R3M	3.3	20	100	1.05	1.35	100KHz /0.25V
CR3012-4R7M	4.7	20	120	0.90	1.25	100KHz /0.25V
CR3012-5R6M	5.6	20	160	0.80	1.10	100KHz /0.25V
CR3012-6R8M	6.8	20	190	0.75	1.00	100KHz /0.25V
CR3012-100M	10	20	265	0.60	0.89	100KHz /0.25V
CR3012-150M	15	20	430	0.45	0.72	100KHz /0.25V
CR3012-220M	22	20	630	0.42	0.55	100KHz /0.25V
Part Number	Inductance (uH)	Tolerance (±%)	DCR(mΩ) ±30%	Isat (A)	Irise (A)	Test Condition
CR3015-1R0N	1.0	30	37	2.32	2.10	100KHz /0.25V
CR3015-1R5N	1.5	30	50	2.00	1.70	100KHz /0.25V
CR3015-2R2N	2.2	30	60	1.60	1.60	100KHz /0.25V
CR3015-3R3M	3.3	20	80	1.32	1.36	100KHz /0.25V
CR3015-4R7M	4.7	20	125	1.10	1.09	100KHz /0.25V
CR3015-6R8M	6.8	20	200	0.85	0.85	100KHz /0.25V
CR3015-100M	10	20	250	0.72	0.77	100KHz /0.25V
CR3015-220M	22	20	460	0.52	0.57	100KHz/0.25V
Part Number	Inductance (uH)	Tolerance (±%)	DCR(mΩ) ±30%	Isat (A)	Irise (A)	Test Condition
CR4018-1R0N	1.0	30	23	4.5	2.50	100KHz /0.25V
CR4018-1R5N	1.5	30	33	3.35	2.34	100KHz /0.25V
CR4018-2R2M	2.2	20	44	2.70	2.00	100KHz /0.25V

CR4018-3R3M	3.3	20	70	2.45	1.90	100kHz /0.25V
CR4018-4R7M	4.7	20	90	1.70	1.70	100kHz /0.25V
CR4018-5R6M	5.6	20	103	1.60	1.50	100kHz /0.25V
CR4018-6R8M	6.8	20	124	1.45	1.30	100kHz /0.25V
CR4018-100M	10	20	200	1.30	1.10	100kHz /0.25V
CR4018-150M	15	20	268	0.94	0.92	100kHz /0.25V
CR4018-220M	22	20	390	0.80	0.80	100kHz /0.25V
CR4018-330M	33	20	560	0.65	0.60	100kHz /0.25V
CR4018-470M	47	20	756	0.57	0.50	100kHz /0.25V
Part Number	Inductance (uH)	Tolerance (±%)	DCR(m Ω ) ±30%	Isat (A)	Irise (A)	Test Condition
CR4020-R33N	0.33	30	13	7.50	3.30	100kHz /0.25V
CR4020-1R0N	1.0	30	28	5.10	2.15	100kHz /0.25V
CR4020-1R2N	1.2	30	29	4.70	2.10	100kHz /0.25V
CR4020-1R5N	1.5	30	35	4.45	1.98	100kHz /0.25V
CR4020-2R2M	2.2	20	40	3.40	1.85	100kHz /0.25V
CR4020-3R3M	3.3	20	70	3.20	1.40	100kHz /0.25V
CR4020-4R7M	4.7	20	80	2.35	1.34	100kHz /0.25V
CR4020-5R6M	5.6	20	95	2.20	1.22	100kHz /0.25V
CR4020-6R8M	6.8	20	125	2.00	1.04	100kHz /0.25V
CR4020-8R2M	8.2	20	150	1.75	1.00	100kHz /0.25V
CR4020-100M	10	20	165	1.60	0.90	100kHz /0.25V
CR4020-120M	12	20	175	1.50	0.88	100kHz /0.25V
CR4020-150M	15	20	230	1.35	0.77	100kHz /0.25V
CR4020-220M	22	20	350	1.05	0.62	100kHz /0.25V
CR4020-330M	33	20	500	0.85	0.49	100kHz /0.25V
CR4020-470M	47	20	710	0.74	0.44	100kHz /0.25V
CR4020-560M	56	20	800	0.68	0.40	100kHz /0.25V
CR4020-680M	68	20	1250	0.60	0.35	100kHz /0.25V
Part Number	Inductance (uH)	Tolerance (±%)	DCR (mΩ ) ± 30%	Isat (A)	Irise (A)	Test Condition
CR4030-R47N	0.47	30	11	7.50	3.50	100kHz /0.25V
CR4030-1R0N	1.0	30	15	5.90	3.40	100kHz /0.25V
CR4030-1R5N	1.5	30	25	4.85	3.30	100kHz /0.25V
CR4030-1R8N	1.8	30	30	4.25	3.20	100kHz /0.25V
CR4030-2R2M	2.2	20	35	4.10	2.95	100kHz /0.25V
CR4030-3R3M	3.3	20	40	3.30	2.40	100kHz /0.25V
CR4030-3R6M	3.6	20	53	3.10	2.30	100kHz /0.25V
CR4030-3R9M	3.9	20	57	3.00	2.10	100kHz /0.25V
CR4030-4R7M	4.7	20	60	2.90	2.00	100kHz /0.25V
CR4030-5R6M	5.6	20	70	2.75	1.95	100kHz /0.25V
CR4030-6R8M	6.8	20	75	2.60	1.70	100kHz /0.25V
CR4030-7R5M	7.5	20	90	2.20	1.65	100kHz /0.25V

CR4030-8R2M	8.2	20	100	2.10	1.60	100kHz /0.25V
CR4030-100M	10	20	115	1.95	1.50	100kHz /0.25V
CR4030-120M	12	20	140	1.70	1.35	100kHz /0.25V
CR4030-150M	15	20	190	1.65	1.15	100kHz /0.25V
CR4030-180M	18	20	215	1.40	1.10	100kHz /0.25V
CR4030-220M	22	20	225	1.30	1.00	100kHz /0.25V
CR4030-330M	33	20	330	1.10	0.84	100kHz /0.25V
CR4030-470M	47	20	500	0.90	0.72	100kHz /0.25V
CR4030-560M	56	20	560	0.85	0.65	100kHz /0.25V
CR4030-680M	68	20	750	0.75	0.55	100kHz /0.25V
CR4030-820M	82	20	950	0.68	0.50	100kHz /0.25V
CR4030-101M	100	20	1150	0.60	0.45	100kHz /0.25V
CR4030-151M	150	20	2350	0.50	0.35	100kHz /0.25V
Part Number	Inductance (uH)	Tolerance (±%)	DCR(mΩ) ±30%	Isat (A)	Irise (A)	Test Condition
CR5015-1R0N	1.0	30	35	4.50	2.80	100kHz /0.25V
CR5015-1R5N	1.5	30	50	3.50	2.50	100kHz /0.25V
CR5015-2R2N	2.2	30	65	3.00	2.20	100kHz /0.25V
CR5015-3R3N	3.3	30	80	2.50	1.90	100kHz /0.25V
CR5015-4R7N	4.7	30	100	2.10	1.60	100kHz /0.25V
CR5015-6R8M	6.8	20	150	1.65	1.40	100kHz /0.25V
CR5015-100M	10	20	200	1.45	1.20	100kHz /0.25V
CR5015-150M	15	20	320	1.20	0.85	100kHz /0.25V
CR5015-220M	22	20	450	1.10	0.75	100kHz /0.25V
Part Number	Inductance (uH)	Tolerance (±%)	DCR (mΩ) ± 30%	Isat (A)	Irise (A)	Test Condition
CR5020-R22N	0.22	30	11	6.00	5.00	100kHz /0.25V
CR5020-R24N	0.24	30	11	6.00	5.00	100kHz /0.25V
CR5020-R47N	0.47	30	15	4.85	3.95	100kHz /0.25V
CR5020-1R0N	1.0	30	20	4.33	3.70	100kHz /0.25V
CR5020-1R2N	1.2	30	25	4.20	3.50	100kHz /0.25V
CR5020-1R5N	1.5	30	26	4.10	3.20	100kHz /0.25V
CR5020-1R8N	1.8	30	30	4.00	3.00	100kHz /0.25V
CR5020-2R2N	2.2	30	38	3.85	2.90	100kHz /0.25V
CR5020-2R7N	2.7	30	45	3.50	2.40	100kHz /0.25V
CR5020-3R3N	3.3	30	46	3.25	2.40	100kHz /0.25V
CR5020-3R9N	3.9	30	50	2.90	2.15	100kHz /0.25V
CR5020-4R7M	4.7	20	65	2.40	2.05	100kHz /0.25V
CR5020-5R6M	5.6	20	72	2.30	1.85	100kHz /0.25V
CR5020-6R8M	6.8	20	92	2.10	1.70	100kHz /0.25V
CR5020-8R2M	8.2	20	100	1.90	1.60	100kHz /0.25V
CR5020-100M	10	20	125	1.80	1.50	100kHz /0.25V
CR5020-150M	15	20	180	1.44	1.25	100kHz /0.25V
CR5020-220M	22	20	250	1.18	1.05	100kHz /0.25V
CR5020-330M	33	20	370	0.97	0.83	100kHz /0.25V

CR5020-470M	47	20	560	0.81	0.70	100KHz /0.25V
CR5020-680M	68	20	850	0.70	0.53	100KHz /0.25V
Part Number	Inductance (uH)	Tolerance (±%)	DCR(mΩ) ±30%	Isat (A)	Irise (A)	Test Condition
CR5030-R47N	0.47	30	10	9.00	5.00	100KHz /0.25V
CR5030-1R0N	1.0	30	15	6.65	4.00	100KHz /0.25V
CR5030-1R5N	1.5	30	16	6.0	3.90	100KHz /0.25V
CR5030-2R2M	2.2	20	23	4.20	3.50	100KHz /0.25V
CR5030-3R3M	3.3	20	30	3.60	3.00	100KHz /0.25V
CR5030-4R7M	4.7	20	35	3.10	2.60	100KHz /0.25V
CR5030-6R8M	6.8	20	52	2.50	2.30	100KHz /0.25V
CR5030-100M	10	20	70	2.10	1.70	100KHz /0.25V
CR5030-150M	15	20	125	1.60	1.40	100KHz /0.25V
CR5030-220M	22	20	180	1.40	1.05	100KHz /0.25V
CR5030-270M	27	20	190	1.30	0.90	100KHz /0.25V
CR5030-330M	33	20	225	1.15	0.80	100KHz /0.25V
CR5030-470M	47	20	325	0.95	0.70	100KHz /0.25V
CR5030-560M	56	30	420	0.89	0.63	100KHz /0.25V
CR5030-680M	68	20	475	0.85	0.68	100KHz /0.25V
CR5030-101M	101	20	720	0.71	0.65	100KHz /0.25V
CR5030-151M	151	20	1050	0.60	0.55	100KHz /0.25V
CR5030-221M	220	20	1300	0.55	0.45	100KHz /0.25V
Part Number	Inductance (uH)	Tolerance (±%)	DCR(m Ω ) ±30%	Isat (A)	Irise (A)	Test Condition
CR5040-1R0N	1.0	30	13	7.35	4.90	100KHz /0.25V
CR5040-1R5N	1.5	30	15	6.30	4.30	100KHz /0.25V
CR5040-1R8N	1.8	30	18	6.10	3.90	100KHz /0.25V
CR5040-2R2N	2.2	30	19	4.90	3.80	100KHz /0.25V
CR5040-2R7N	2.7	30	22	4.30	3.60	100KHz /0.25V
CR5040-3R3N	3.3	30	24	3.95	3.40	100KHz /0.25V
CR5040-3R9N	3.9	30	27	3.55	3.20	100KHz /0.25V
CR5040-4R7M	4.7	20	30	3.50	3.00	100KHz /0.25V
CR5040-5R6M	5.6	20	33	3.20	2.80	100KHz /0.25V
CR5040-6R8M	6.8	20	43	2.90	2.50	100KHz /0.25V
CR5040-8R2M	8R2	20	55	3.00	2.30	100KHz /0.25V
CR5040-100M	10	20	64	2.35	2.10	100KHz /0.25V
CR5040-150M	15	20	86	2.00	2.00	100KHz /0.25V
CR5040-220M	22	20	129	1.60	1.50	100KHz /0.25V
CR5040-270M	27	20	165	1.50	1.30	100KHz /0.25V
CR5040-330M	33	20	188	1.30	1.20	100KHz /0.25V
CR5040-390M	39	20	225	1.20	1.10	100KHz /0.25V
CR5040-470M	47	20	270	1.10	1.00	100KHz /0.25V

CR5040-680M	68	20	400	0.90	0.80	100KHz /0.25V
CR5040-101M	100	20	560	0.75	0.70	100KHz /0.25V
Part Number	Inductance (uH)	Tolerance (±%)	DCR (m Ω ) ±30%	Isat (A)	Irise(A)	Test Condition
CR6015-1R2N	1.2	30	35	4.20	2.80	100KHz /0.25V
CR6015-2R2N	2.2	30	50	3.10	2.30	100KHz /0.25V
CR6015-3R3N	3.3	30	60	2.60	2.10	100KHz /0.25V
CR6015-4R7M	4.7	20	90	2.10	1.90	100KHz /0.25V
CR6015-5R6M	5.6	20	92	2.00	1.80	100KHz /0.25V
CR6015-6R8M	6.8	20	115	1.80	1.65	100KHz /0.25V
CR6015-100M	10	20	155	1.45	1.35	100KHz /0.25V
CR6015-150M	15	20	220	1.20	1.20	100KHz /0.25V
CR6015-220M	22	20	320	1.00	1.00	100KHz /0.25V
Part Number	Inductance (uH)	Tolerance (±%)	DCR (m Ω ) ±30%	Isat (A)	Irise (A)	Test Condition
CR6020-R68N	1.0	30	15	7.50	3.80	100KHz /0.25V
CR6020-1R0N	1.0	30	20	4.80	3.50	100KHz /0.25V
CR6020-1R2N	1.2	30	20	4.30	3.50	100KHz /0.25V
CR6020-1R5N	1.5	30	25	4.30	3.20	100KHz /0.25V
CR6020-2R2N	2.2	30	35	3.75	2.75	100KHz /0.25V
CR6020-3R3N	3.3	30	45	3.15	2.60	100KHz /0.25V
CR6020-4R7N	4.7	30	58	3.00	2.00	100KHz /0.25V
CR6020-5R6M	5.6	20	70	2.40	1.90	100KHz /0.25V
CR6020-6R8M	6.8	20	85	2.20	1.80	100KHz /0.25V
CR6020-100M	10	20	120	1.75	1.40	100KHz /0.25V
CR6020-150M	15	20	160	1.50	1.20	100KHz /0.25V
CR6020-220M	22	20	240	1.25	1.00	100KHz /0.25V
CR6020-270M	27	20	350	1.15	0.95	100KHz /0.25V
CR6020-330M	33	20	400	1.10	0.90	100KHz /0.25V
CR6020-470M	47	20	500	1.00	0.80	100KHz /0.25V
Part Number	Inductance (uH)	Tolerance (±%)	DCR (m Ω ) ±30%	Isat (A)	Irise (A)	Test Condition
CR6028-1R0N	1.0	30	12	6.70	4.60	100KHz /0.25V
CR6028-1R5N	1.5	30	16	6.00	4.30	100KHz /0.25V
CR6028-2R2N	2.2	30	20	5.10	3.75	100KHz /0.25V
CR6028-3R3N	3.3	30	25	3.63	3.40	100KHz /0.25V
CR6028-4R7N	4.7	30	33	3.00	3.00	100KHz /0.25V
CR6028-5R6N	5.6	30	45	2.80	2.45	100KHz /0.25V
CR6028-6R8M	6.8	20	56	2.60	2.40	100KHz /0.25V
CR6028-8R2M	8.2	20	68	2.40	2.25	100KHz /0.25V
CR6028-100M	10	20	78	2.05	1.90	100KHz /0.25V

CR6028-120M	12	20	88	1.80	1.70	100KHz /0.25V
CR6028-150M	15	20	125	1.75	1.50	100KHz /0.25V
CR6028-180M	18	20	130	1.55	1.45	100KHz /0.25V
CR6028-220M	22	20	140	1.45	1.40	100KHz /0.25V
CR6028-270M	27	20	180	1.40	1.30	100KHz /0.25V
CR6028-330M	33	20	220	1.35	1.10	100KHz /0.25V
CR6028-390M	39	20	225	1.25	1.10	100KHz /0.25V
CR6028-470M	47	20	280	1.15	1.05	100KHz /0.25V
CR6028-680M	68	20	420	0.95	0.85	100KHz /0.25V
CR6028-820M	82	20	550	0.80	0.70	100KHz /0.25V
CR6028-101M	100	20	670	0.65	0.60	100KHz /0.25V
Part Number	Inductance (uH)	Tolerance (±%)	DCR(mΩ) ±30%	Isat (A)	Irise (A)	Test Condition
CR6045-1R0N	1.0	30	10	9.00	5.10	100KHz /0.25V
CR6045-1R5N	1.5	30	12	7.50	4.75	100KHz /0.25V
CR6045-1R8N	1.8	30	13	7.50	4.60	100KHz /0.25V
CR6045-2R2N	2.2	30	13	6.50	4.60	100KHz /0.25V
CR6045-3R3N	3.3	30	20	5.30	3.20	100KHz /0.25V
CR6045-3R9N	3.9	30	20	4.90	3.20	100KHz /0.25V
CR6045-4R7N	4.7	30	24	4.50	3.00	100KHz /0.25V
CR6045-5R6N	5.6	30	31	3.70	2.80	100KHz /0.25V
CR6045-6R8M	6.8	20	33	3.30	2.70	100KHz /0.25V
CR6045-8R2M	8.2	20	45	3.20	2.60	100KHz /0.25V
CR6045-100M	10	20	52	3.00	2.50	100KHz /0.25V
CR6045-120M	12	20	58	2.80	2.20	100KHz /0.25V
CR6045-150M	15	20	77	2.50	1.90	100KHz /0.25V
CR6045-220M	22	20	115	2.00	1.50	100KHz /0.25V
CR6045-270M	27	20	120	1.90	1.48	100KHz /0.25V
CR6045-330M	33	20	150	1.60	1.45	100KHz /0.25V
CR6045-390M	39	20	180	1.50	1.25	100KHz /0.25V
CR6045-470M	47	20	220	1.40	1.20	100KHz /0.25V
CR6045-560M	56	20	260	1.30	1.10	100KHz /0.25V
CR6045-680M	68	20	290	1.20	0.90	100KHz /0.25V
CR6045-820M	82	20	355	1.10	0.85	100KHz /0.25V
CR6045-101M	100	20	430	1.00	0.80	100KHz /0.25V
CR6045-121M	120	20	530	0.85	0.75	100KHz /0.25V
CR6045-151M	150	20	760	0.80	0.70	100KHz /0.25V
CR6045-181M	180	20	845	0.75	0.65	100KHz /0.25V
CR6045-221M	220	20	890	0.63	0.55	100KHz /0.25V
CR6045-331M	330	20	1410	0.51	0.48	100KHz /0.25V
Part Number	Inductance (uH)	Tolerance (±%)	DCR(mΩ) ±30%	Isat (A)	Irise (A)	Test Condition
CR8040-R56N	0.56	30	5	11.5	7.6	1MHz /0.25V
CR8040-1R0N	1.0	30	8	9.85	6.30	100KHz /0.25V
CR8040-1R5N	1.5	30	10	8.15	5.65	100KHz /0.25V
CR8040-2R2N	2.2	30	12	7.10	5.15	100KHz /0.25V
CR8040-3R3N	3.3	30	17	6.50	4.40	100KHz /0.25V
CR8040-4R7N	4.7	30	20	5.90	4.00	100KHz /0.25V
CR8040-5R6N	5.6	30	24	5.50	3.80	100KHz /0.25V

CR8040-6R8M	6.8	20	28	4.55	3.60	100KHz /0.25V
CR8040-8R2M	8.2	20	35	4.20	3.40	100KHz /0.25V
CR8040-100M	10	20	37	3.60	3.10	100KHz /0.25V
CR8040-150M	15	20	56	2.95	2.50	100KHz /0.25V
CR8040-220M	22	20	74	2.40	2.00	100KHz /0.25V
CR8040-270M	27	20	80	2.15	1.90	100KHz /0.25V
CR8040-330M	33	20	100	2.05	1.70	100KHz /0.25V
CR8040-470M	47	20	158	1.75	1.50	100KHz /0.25V
CR8040-560M	56	20	160	1.55	1.40	100KHz /0.25V
CR8040-680M	68	20	196	1.45	1.20	100KHz /0.25V
CR8040-101M	100	20	295	1.15	1.00	100KHz /0.25V
CR8040-151M	150	20	470	1.10	0.80	100KHz /0.25V
CR8040-171M	170	20	538	0.95	0.75	100KHz /0.25V
CR8040-181M	180	20	610	0.90	0.75	100KHz /0.25V
CR8040-221M	220	20	660	0.85	0.70	100KHz /0.25V
CR8040-331M	330	20	970	0.68	0.55	100KHz /0.25V
CR8040-471M	470	20	1400	0.60	0.48	100KHz /0.25V
CR8040-681M	680	20	1750	0.50	0.45	100KHz /0.25V

**Isat (A):**

DC Saturation Current that will cause initial inductance to drop approximately 30% max.

**Irise(A)**

DC Current that will cause an approximate  $\Delta T$  of 40 °C

**Measuring Instrument :**

L:HI0KI3532-50

DCR:HI0KI 3540

I sat / Irise:HP4284+42841A



### 3. General Characteristics

3-1. Storage Temperature range :  $-40^{\circ}\text{C} \sim +105^{\circ}\text{C}$

3-2. Operating temperature range:  $-40^{\circ}\text{C} \sim +125^{\circ}\text{C}$  (Including coil's self temperature rise)

3-3. External appearance : No external defects can be found in the visual inspection.

3-4. Electrode strength : No electrode detachment should be found when the device is pushed in two directions of X and Y with the force of 10.0N for  $10 \pm 2$  seconds after soldering between copper plate and the electrodes.  
(Refer to figure at right)

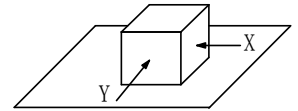

3-5. Vibration test : Inductance deviation is within  $\pm 10.0\%$  after 1 hour sweeping vibration in each three directions, namely, forward and backward, up and down, right and left. The frequency is  $10 \sim 55 \sim 10\text{Hz}$  and the amplitude of 1 minute cycle is 1.5mm PP.

3-6. Recommended reflow condition:

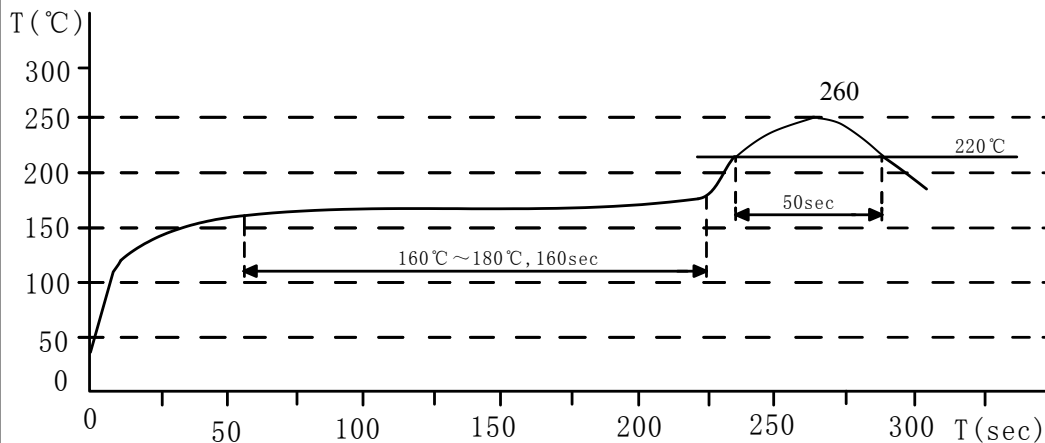

3-7. Humidity test : Inductance deviation is within  $\pm 5.0\%$  after  $96 \pm 4$  hours test under the condition of relative humidity of  $90 \sim 95\%$  and temperature of  $60 \pm 2^{\circ}\text{C}$ , and 1 hour storage under room ambient conditions after the device is wiped with dry cloth.

**LEAD-FRE**



#### 4. Construction and materials

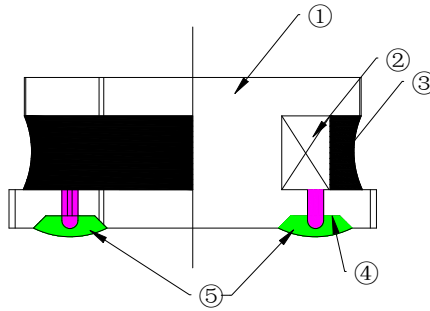

No.	Part name	Material	Baochuangda P/N
①	Drum Core	Ni-Zn Ferrite Core	YN/MT
②	Wire	Polyurethane enameled copper wire	3210200
③	Adhesive	Epoxy Resin Magnetic Powder	7001007
④	Plating Electrodes	Plating: Ag 10-20 $\mu\text{m}$ Ni 1-3 $\mu\text{m}$ Sn 3-7 $\mu\text{m}$	
⑤	Outer Electrodes	Top surface solder coating Sn96.5%、 Ag3%、Cu0.5% 350 $\mu\text{m}$ Typ. thickness	