

SPECIFICATION FOR APPROVAL

承 认 书

CUSTOMER 客户名称:	NUMBER 编 号: B-19010801
DESCRIPTION 品 名: 共模滤波器	QUANTITY 数 量:
PART NO. 型 号: BCCM1005-SERIES	DATE 日 期: 2018/1/8
CUSTOMER PART NO. 客户料号:	NOTE 注 解:

APPROVAL SIGNATURE 客户承认签章

APPROVED BY 核 准	Q. C. DEPT. 品 管	CHECKED BY 核 查	DRAWN BY 制 作

深圳市宝创达电子有限公司

SHENZHEN BAOCHUANGDA ELECTRONICS CO., LTD.

地址: 深圳市龙华区观湖街道横坑河西村77号A栋2楼

Add: 2 / f, building A, no.77, hexi village, guanhu street ,
longhua district, shenzhen

Tel: 0755-29736760 Fax: 0755-28056434

客户名称 CUSTOMER		客户品名 CUSTOMER P/N		版别 REV.	A
产品类型 PRODUCT TYPE	COMMON MODE FILTER	品名 OURS P/N	BCCM1005-SERIES	文件编号 FILE NO.	B-19010801

一.外观图/DIMENSION (单位/UNIT :
mm)

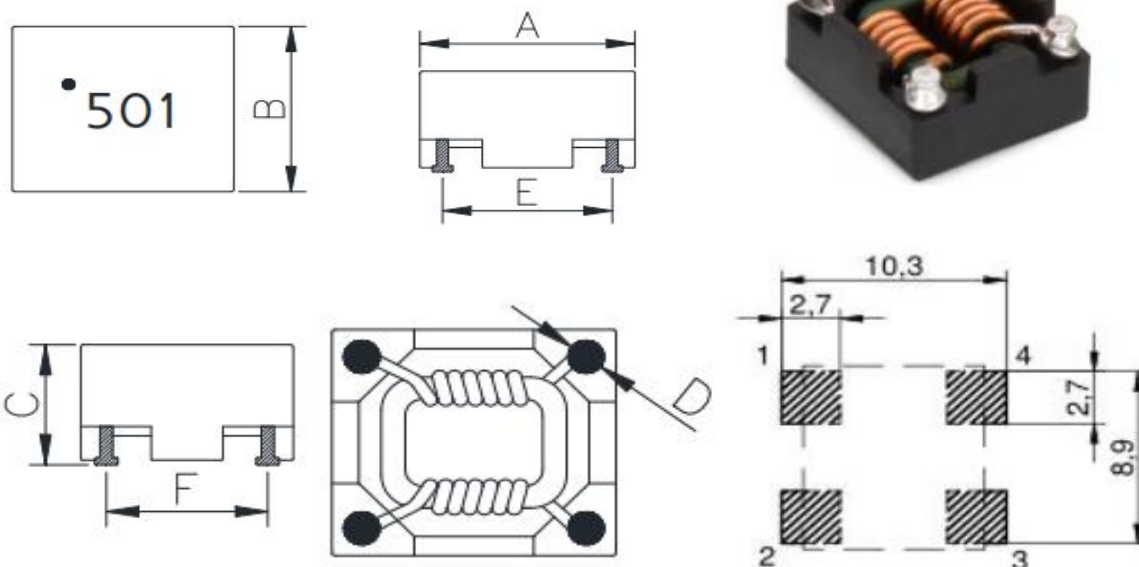

Land Pattern

A	9.5 ±0.3
B	8.3 ±0.3
C	5.3 Max
D	1.2 Typ
E	7.5 Typ
F	6.3 Typ

二.电路图/CIRCUIT DIAGRAM

三.注意事项/NOTE :

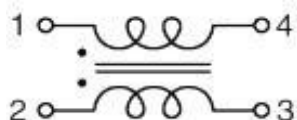

- 1.印字：白色
- 2.平整度：0.12MM MAX

四.电气特性/ELECTRICAL CHARACTERISTIC

Products No.	Common mode Impedance @100MHz (Ω)	Inductance (μ H) @100KHz/0.1V	DCR (m Ω) Max.	Rated Current (A) Max.	Insulation Test Voltage (AC)Max.	Marking
BCCM1005-2-501T	500 (Typ)	5 (Typ)	5.5	5.0	500V	501
BCCM1005-2-801T	800 (Typ)	9 (Typ)	11	3.5	500V	801
BCCM1005-2-102T	1000 (Typ)	11 (Typ)	30	2.5	500V	102
BCCM1005-2-222T	2200 (Typ)	30 (Typ)	60	1.4	500V	222

- (1).Rated Current: Temp.rise 40°C Typ (2).Operating Temperature: -40°C up to +125°C
 (3).Storage Temperature: -20°C up to +40°C, 75% RH max.

客户名称 CUSTOMER		客户品名 CUSTOMER P/N		版别 REV.	A
产品类型 PRODUCT TYPE	COMMON MODE FILTER	品名 OURS P/N	BCCM1005-SERIES	文件编号 FILE NO.	B-19010801

五.材料清单/MATERIAL LIST

NO.	ITEM	DESCRIPTION	
1	CORE	FERRITE	
2	CASE	DAP	
3	WIRE	P180 Grd1	
4	SOLDER	Sn99.3:Cu0.7	
5	INK	WHITE	

六.编带规格/TAPING SPECIFICATIONS

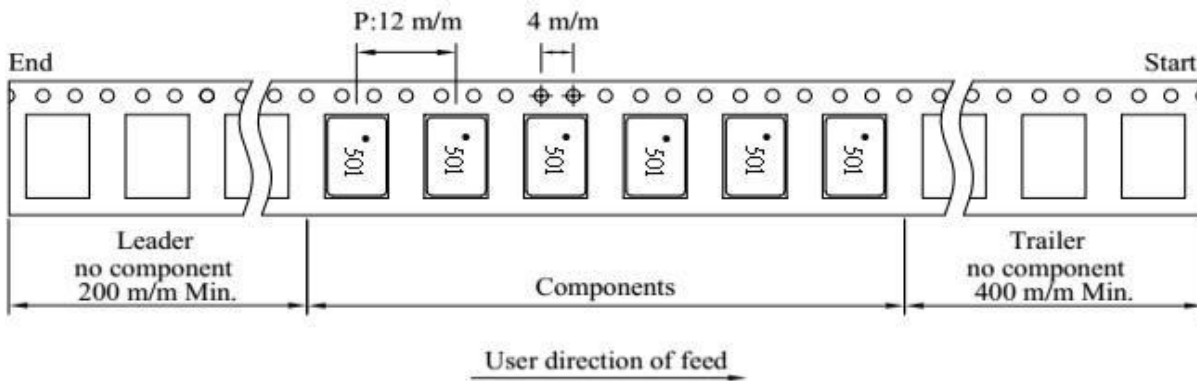

Adhesive strength of cover tape is 20 to 120 gf
The conduction band direction

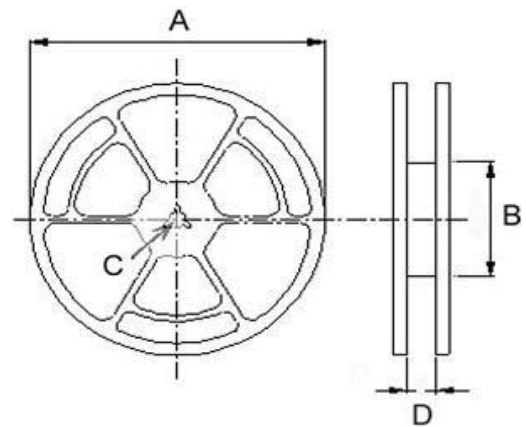
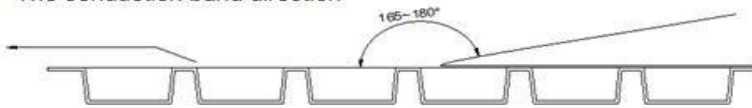

Reel Dimensions (Unit: mm)

Quantity

A	B	C	D	Pcs/Reel
330	100	13	16.5	1000

客户名称 CUSTOMER		客户品名 CUSTOMER P/N		版别 REV.	A
产品类型 PRODUCT TYPE	COMMON MODE	品名 OURS P/N	BCCM1005-SERIES	文件编号 FILE NO.	B-19010801

七.特征曲线/CHARACTERISTICS(REFERENCE)

BCCM1005-2-501T

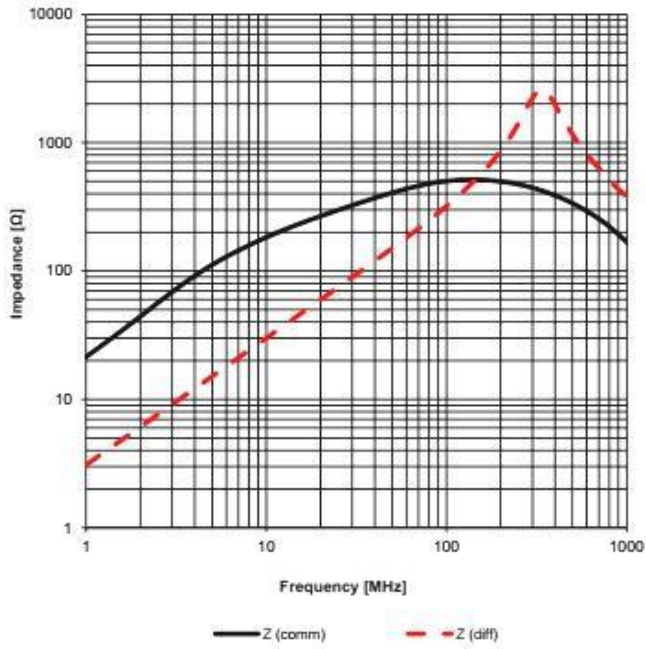

BCCM1005-2-801T

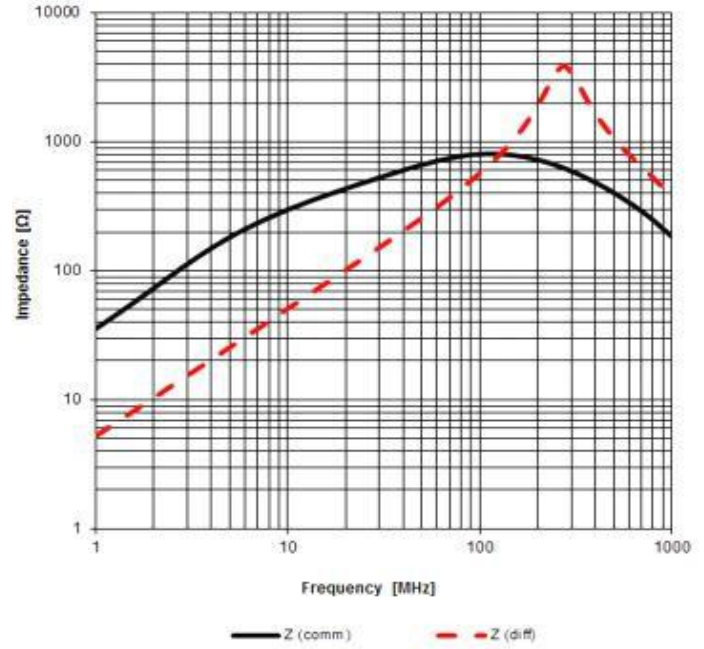

BCCM1005-2-102T

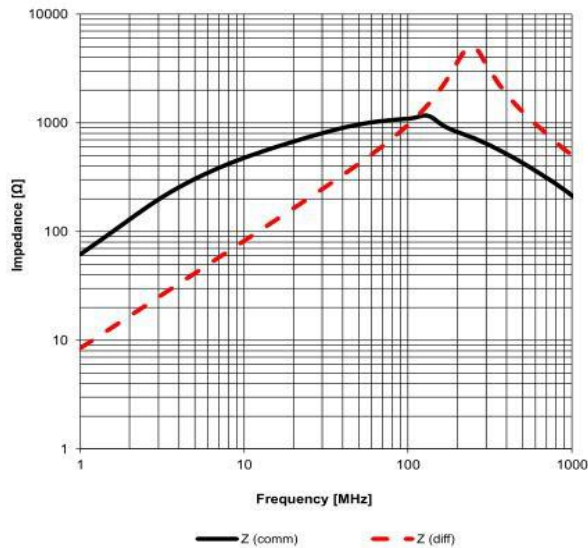

BCCM1005-2-222T

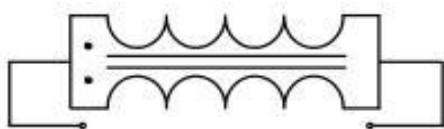
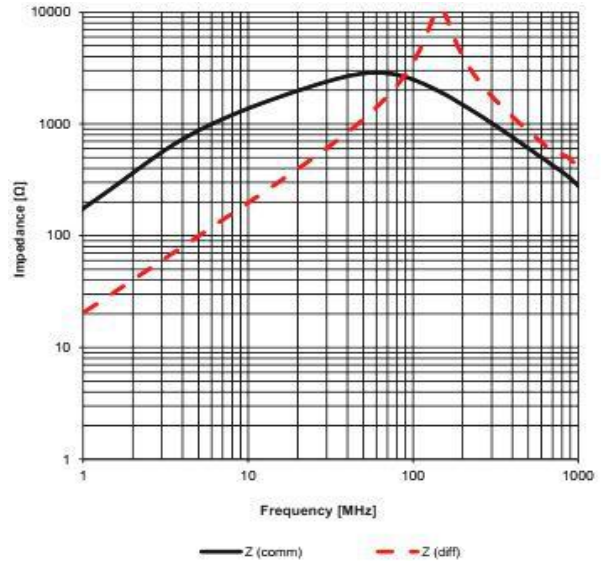

Common Mode

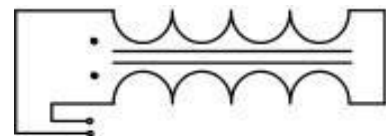

Differential Mode

客户名称 CUSTOMER		客户品名 CUSTOMER		版别 REV.	A
产品类型 PRODUCT TYPE	COMMON MODE FILTER	品名 OURS P/N	BCCM1005-SERIES	文件编号 FILE NO.	B-19010801

八.可靠性测试/RELIABILITY TESTING

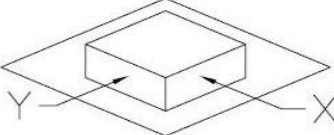
Operating Temperature	- 40 to +125 °C (Contain Heating coil)
Appearance Inspection	No external defects by visual inspection
Terminal Strength 	After soldering , between copper plaet and terminals of coils , push in two directions of X , Y with standing 10N(1.02kg) for10+/-2 sec. Terminal should not peel off. (Refer to figure at right)
Heat endurance of reflow soldering	Refer to figure
Insulating resistance	Over 100 MΩ at 100V D.C . between wire and core
Dielectric Strength	Apply at 0.5KV 3mA for 1 minute between wire and core
Temperature characteristics	Inductance coefficient (0~2,000) × 10 / °C (- 40~ + 125 °C)
Humidity characteristics	Inductance deviation within ± 10% , after 96 hours in 90~95% relative humidity at 40 ± 2 °C and 1 hours drying under normal condition

A test is made under the above mentioned condition , and it is kept for 2 hours in the normal

IR Reflow profile

Temperature °C

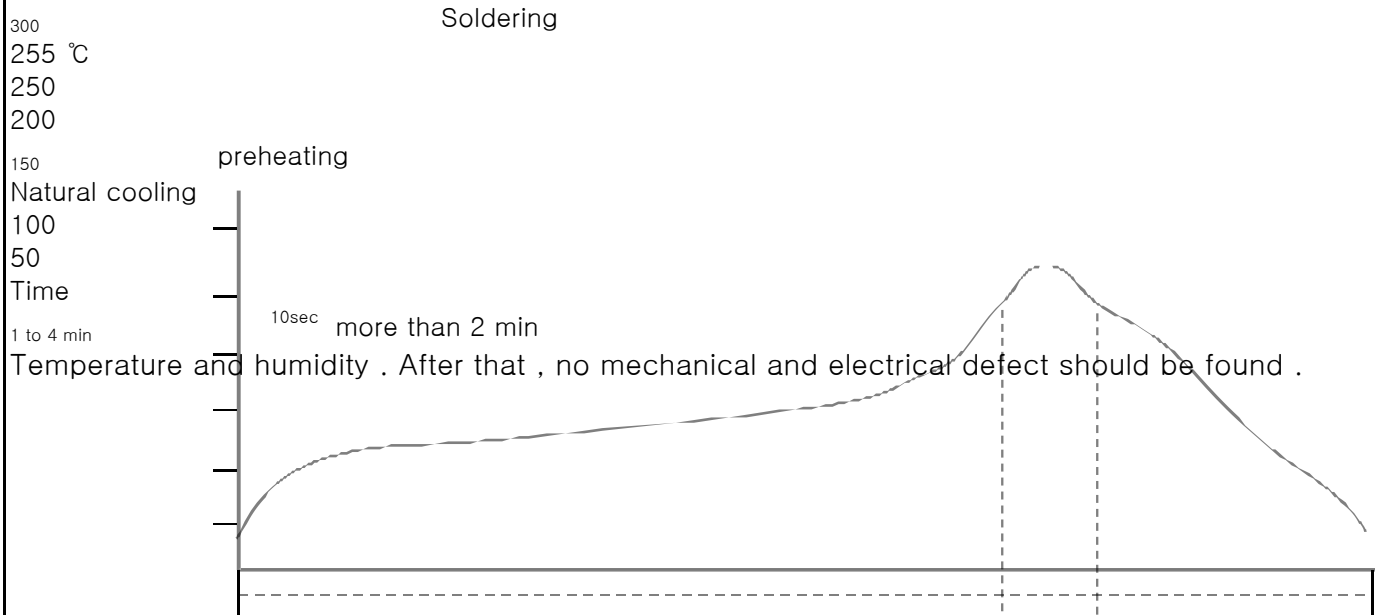

Temperature and humidity . After that , no mechanical and electrical defect should be found .

客户名称 CUSTOMER		客户品名 CUSTOMER P/N		版别 REV.	A
产品类型 PRODUCT TYPE	COMMON MODE FILTER	品名 OURS P/N	BCCM1005-SERIES	文件编号 FILE NO.	B-19010801

九.包装方式/PACKING LIST

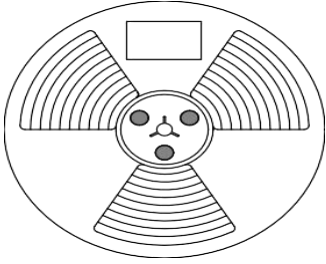
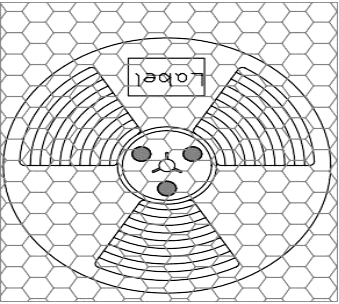
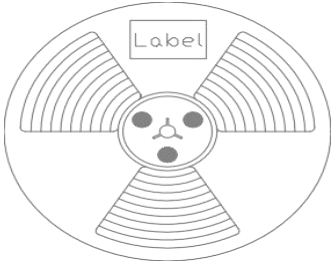
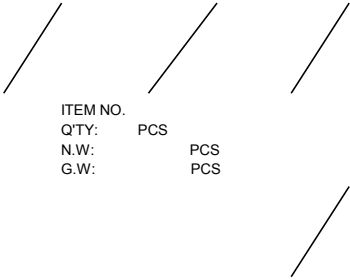
	<p>1、轮盘规格：13(直径330mm)数量：1000PCS/盘</p>
	<p>2、数量：1000PCS/袋.</p>
	<p>3、数量：3000PCS/盒</p>
 <p>ITEM NO. Q'TY: PCS N.W: PCS G.W: PCS</p>	<p>4、数量：15000PCS/箱. 作业说明：当尾数箱不足一整箱时需用内盒或填充物装满.</p>