

UU共模电感

SHAPES AND DIMENSIONS 外形尺寸 (Unit:mm)

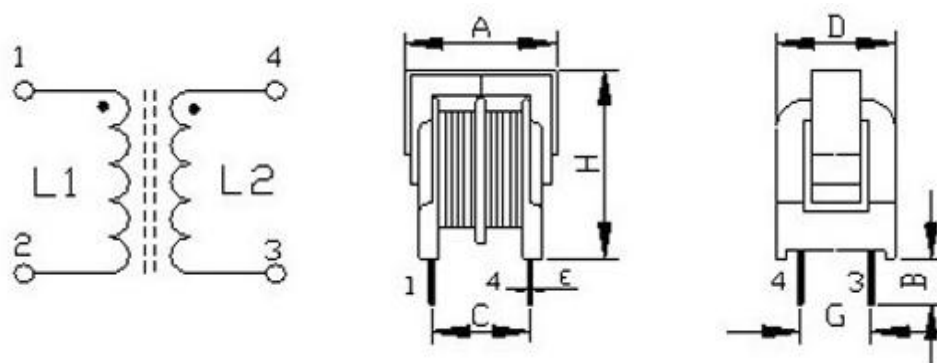

立式

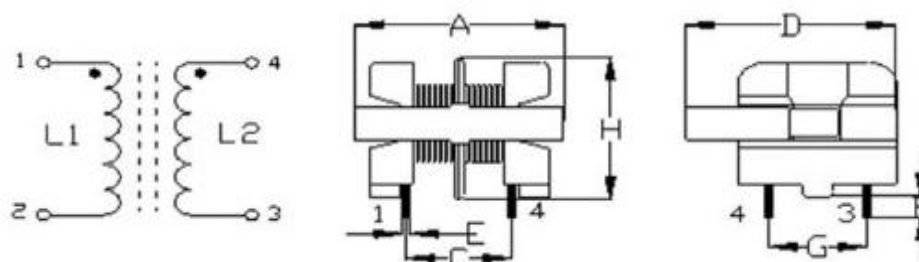

卧式

型号	A	B	C	D	E	G	H
UU9.8	15.6	4±1.0	8±0.5	10.6	0.6±0.5	7±0.5	16
UU9.8卧式	15.6	4±1.0	8±0.5	14.8	0.6±0.5	7±0.5	12.5
UU10.5	17.3	4±1.0	13±0.5	16	0.7±0.5	10±0.5	21
UU16	23	4±1.0	13±0.5	18.5	0.7±0.5	10±0.5	23
UU16卧式	22.6	4±1.0	13±0.5	23.5	0.7±0.5	10±0.5	18.5

UU9.8 Type

modle	INDCTANCE (mH)MIN	Rted Current (A)	DC Resistance (Ω/line) Max
uu9.8-10mH	10	0.1	8
uu9.8-8mH	8	0.2	6
uu9.8-5mH	5	0.3	3
uu9.8-2mH	2	0.5	1
uu9.8-1mH	1	0.7	0.6

uu9.8-0.5mH	0.5	1	0.3
-------------	-----	---	-----

UU10.5 Type

modle	INDCTANCE (mH)MIN	Rted Current (A)	DC Resistance (Ω /line) Max
uu10.5-10mH	10	0.3	3
uu10.5-8mH	8	0.4	2
uu10.5-5mH	5	0.5	1.5
uu10.5-4mH	4	0.7	1
uu10.5-3mH	3	0.8	0.8
uu10.5-2mH	2	0.9	0.6
uu10.5-1.5mH	1.5	1	0.5
uu10.5-1.3mH	1.3	1.3	0.4
uu10.5-1mH	1	1.5	0.3
uu10.5-0.6mH	0.6	2	0.2

UU16 Type

modle	INDCTANCE (mH)MIN	Rted Current (A)	DC Resistance (Ω /line) Max
uu16-30mH	30	0.4	2.8
uu16-20mH	20	0.5	1.6
uu16-10mH	10	0.6	1.2
uu16-8mH	8	0.8	0.8
uu16-6mH	6	1	0.5
uu16-4mH	4	1.1	0.4
uu16-3mH	3	1.2	0.3
uu16-1.5mH	1.5	1.5	0.2