

SPECIFICATION FOR APPROVAL

承 认 书

CUSTOMER

客户名称:

NUMBER

编 号: Y-21070207

DESCRIPTION

品 名: 贴片共模电感

QUANTITY

数 量: 10pcs

PART NO.

型 号: BCDM126-2-472T

DATE

日 期: 2021/7/2

CUSTOMER PART NO.

客户料号:

NOTE

注 解:

APPROVAL SIGNATURE 客户承认签章

APPROVED BY 核 准	Q. C. DEPT. 品 管	CHECKED BY 核 查	DRAWN BY 制 作

深圳市宝创达电子有限公司

SHENZHEN BAICHUANGDA ELECTRONICS CO., LTD.

地址: 深圳市龙华区观澜街道横坑河西村77号A栋2楼

Add: 2nd floor building A no.77 hexi village guanlan
Street longhua district shenzhen

Tel: 0755-29736760

Fax: 0755-28056434

客户 CUSTOMER		规格型号 PART NO	BCDM126-2-472T
----------------	--	-----------------	----------------

1: 外形尺寸: (单位: mm)

OVERALL DIMENSION (UNIT: mm)

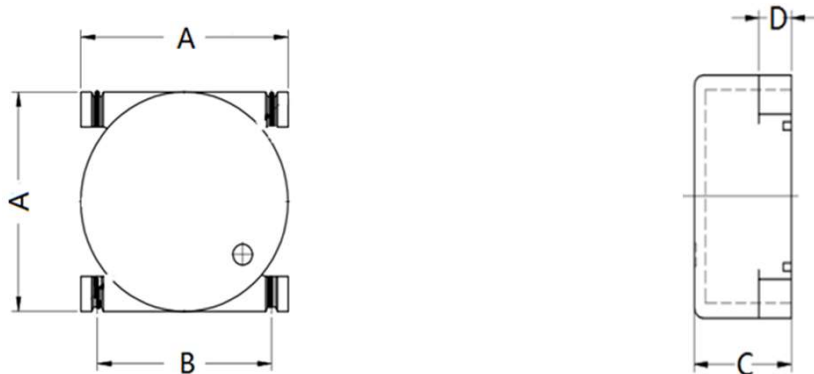

尺寸	A	B	C	D
单位mm	13.0MAX	10.5±0.5	6.5MAX	2±0.5

2: 接线图: 两组线分绕

WIRING DIAGRAM: SEPARATE WINDING

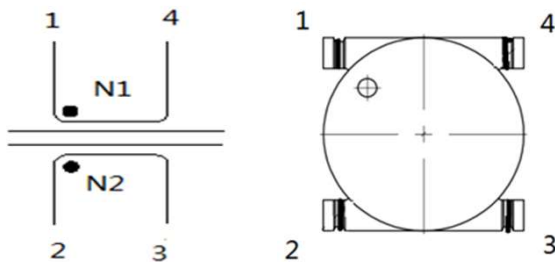

No polarity

3: 焊接尺寸: mm

WELDING DIMENSION: mm

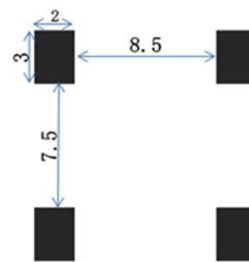

4: 电气性能参数(ELECTRICAL PARAMETERS)

电感量及允许偏差 (1KHz/ 0.25V)	L14=L23: 4.7mH(MIN)
直流电阻 DC RESISTANCE	220 mΩ (MAX)
额定电流 RATED CURRENT	0.6A MAX
阻抗(2MHz) IMPEDANCE	4700 Ω MIN

测试仪表 (MEASUREMENT INSTRUMENT):

HM2791 HM2801 HP4285
CH19073

在最坏情况下建议零件的温度不超过+125° C。(It is recommended that the temperature of the part does not exceed +125° C under worst case conditions.)

贮存环境(Storage conditions):存放环境温度-20° C至60° C,相对湿度不高于70%,并存放在不含硫和氯的空气气氛中(请不要直接暴露在阳光下) Storage ambient temperature-20° C to 60° C, 70%RH or less, and isolate the parts from sulphuric and chloric atmosphere. (Please don't expose to the sun directly)

Note:	SPEC. NO. : Y-21070205 1/2\
-------	-----------------------------------

客户 CUSTOMER		规格型号 PART NO	BCDM126-2-472T
----------------	--	-----------------	----------------

零件工作温度(Operating temperature of parts): -40° C - 125° C

温升 (Temperature Rise) : < 55K

电性能试验条件 (Est conditions of Electrical Properties) : 20° C、相对湿度33% (20° C, 33% RH)

没有特殊规定下 (If not specified differently)

5: 阻抗曲线图 (IMPEDANCE CURVE)

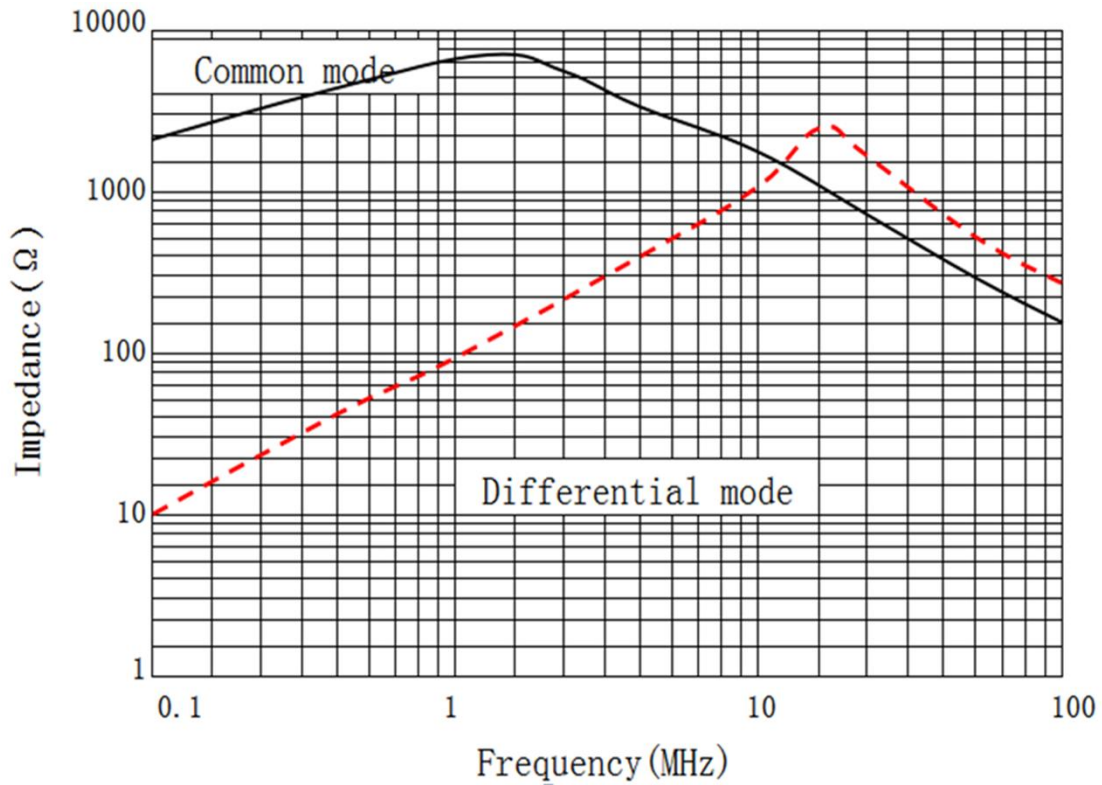

6: 包装 (PACKING)

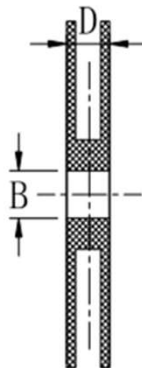
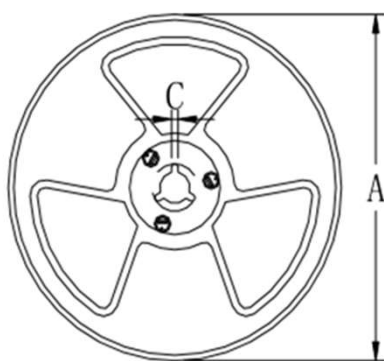

规格	13"	7"
尺寸	Φ	Φ
A	330±2.0	178±2.0
B	Φ90 ± 2.0	
C	2.3	
D	30.5	

Note:	SPEC. NO. : Y-21070207 2/2
-------	----------------------------------